



## PS-121000S **12V 100.0 AH @ 20-hr.** **12V 95.2 AH @ 10-hr.**

Rechargeable Sealed Lead Acid Battery  
PS – General Purpose Series

### TERMINALS: (mm)

**T6:** Threaded insert with 6mm stud fastener

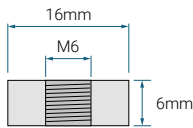

Torque: 3.9~5.4 Nxm

**U:** Universal terminals: Heavy-duty posts with 'nut & bolt' fasteners

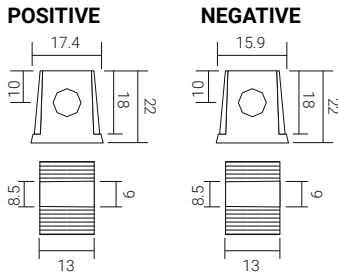

Torque: 11.0~14.7 Nxm

### DIMENSIONS: inch (mm)

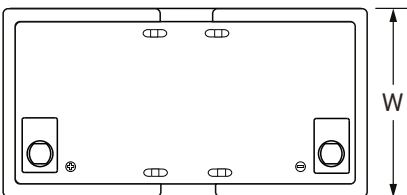

**L:** 12.00 (305)  
**W:** 6.60 (168)  
**H:** 8.15 (207)  
**HT:** 8.98 (228)

Tolerances are +/- 0.04 in. (+/- 1mm) and +/- 0.08 in. (+/- 2mm) for height dimensions. All data subject to change without notice.

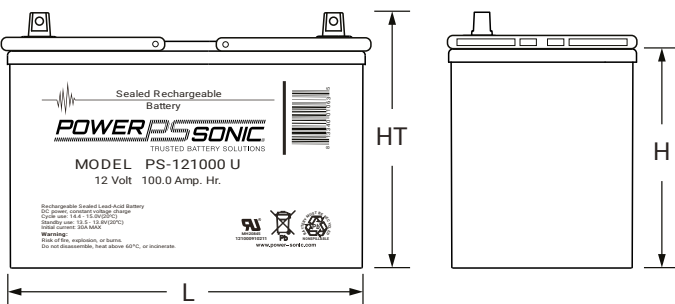

### CORPORATE HEADQUARTERS (USA AND INTERNATIONAL EXCLUDING EMEA)

**Power-Sonic Corporation**  
7550 Panasonic Way, San Diego,  
California 92154  
**T:** +1 (619) 661 2020  
**F:** +1 (619) 661 3650  
**E:** customer-service@power-sonic.com

To ensure safe and efficient operation always refer to the latest edition of our Technical Manual, as published on our website.  
© 2018, Power-Sonic Corporation. All rights reserved. All trademarks are the property of their respective owners.  
All data subject to change without notice. E&O.E

### FEATURES

- 10 – 12 year design life
- Absorbent Glass Mat (AGM) technology for superior performance
- Valve regulated, maintenance free spill proof construction
- Power/volume ratio yielding excellent energy density
- Rugged vibration and impact resistant ABS case and cover
- Gas recombination technology

### APPROVALS

- Approved for transport by air. D.O.T., I.A.T.A., F.A.A. and C.A.B. certified
- U.L. recognized
- ISO9001:2015 – Quality management systems

### PERFORMANCE SPECIFICATIONS

<b>Nominal Voltage</b>	12 volts (6 cells)
<b>Nominal Capacity</b>	
20-hr. (5.00A to 10.50 volts)	100.0 AH
10-hr. (9.52A to 10.50 volts)	95.2 AH
5-hr. (16.6A to 10.20 volts)	83.0 AH
1-hr. (57.9A to 9.00 volts)	57.9 AH
<b>Approximate Weight</b>	67.5 lbs. (30.6 kg)
<b>Internal Resistance (approx.)</b>	4.9 milliohms
<b>Max Short-Duration Discharge Current (10 Sec.)</b>	750.0 amperes
<b>Shelf Life (% of nominal capacity at 68°F (20°C))</b>	
1 Month	97%
3 Month	91%
6 Month	83%
<b>Operating Temperature Range</b>	
Charge	5°F (-15°C) to 122°F (50°C)
Discharge	-4°F (-20°C) to 140°F (60°C)
<b>Case</b>	ABS Plastic
<b>Power Sonic Chargers</b>	PSC-1210000A-C PSC-1210000-PC PSC-1220000-PC

**PS-121000S** 12V 100.0 AH @ 20-hr.  
12V 95.2 AH @ 10-hr.

Rechargeable Sealed Lead Acid Battery  
PS – General Purpose Series

**SHELF LIFE & STORAGE**

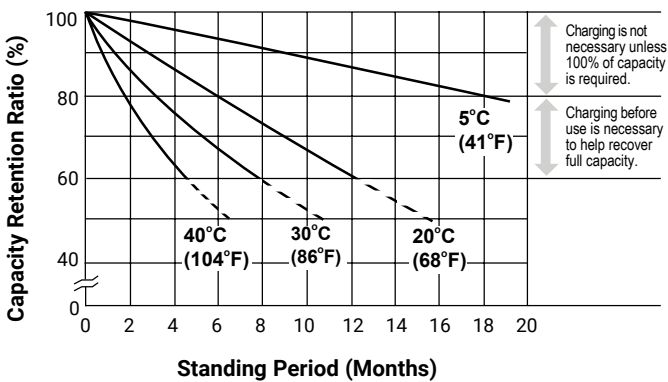

**LIFE CHARACTERISTICS IN STAND-BY USE**

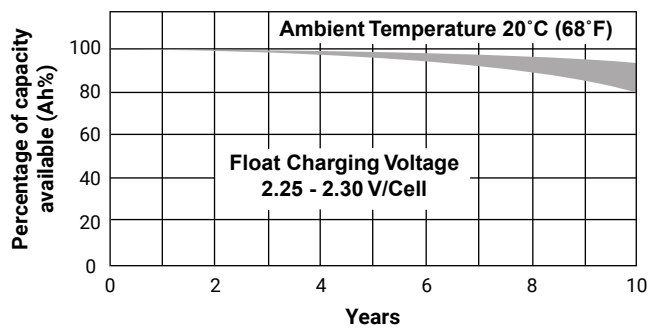

**CHARGING**

**Cycle Applications:** Apply constant voltage charge at 2.35v/c – 2.45v/c (14.1 – 14.7v for 12v Monobloc) at 20°C. Initial charging current should be set at less than 0.25C Amps. Switch to float charge to avoid overcharging.

**“Float” or “Stand-By” Service:** Apply constant voltage charge of 2.25v/c – 2.30v/c (13.5 to 13.8 volts for 12v Monobloc) at 20°C. When held at this voltage, the battery will seek its own current level and maintain itself in a fully charged condition.

**Temperature Compensation:** Charging Voltage for both Cyclic and Standby applications should be regulated in relation to ambient temperature. As temperature rises charging voltage should be reduced to prevent overcharge and increased as temperature falls to avoid undercharge.

For further charging information including temperature compensation factors, see Power Sonic Technical Manual/ Power Sonic Charger specifications.

**APPLICATIONS**

- General purpose
- Medical
- Emergency lighting
- Fire and security

**CORPORATE HEADQUARTERS**  
(USA AND INTERNATIONAL EXCLUDING EMEA)

Power-Sonic Corporation  
7550 Panasonic Way, San Diego,  
California 92154  
T: +1 (619) 661 2020  
F: +1 (619) 661 3650  
E: customer-service@power-sonic.com

**CHARGERS**

Power Sonic offers a wide range of chargers suitable for batteries with a variety of capacities.

Please refer to our website for more information on our switch mode and transformer type chargers.

Please contact our technical department for advice if you have difficulty in locating a suitable charger.

**FURTHER INFORMATION**

Please refer to our website [www.power-sonic.com](http://www.power-sonic.com) for a complete range of useful downloads, such as product catalogs, material safety data sheets (MSDS), ISO certification, etc.

